

LS-10 Series – Slim Profile for Interstitial Liquid Sensing

The GEMS LS-10 liquid sensor accurately detects the presence of liquid in fiberglass double-wall tanks, containment sumps and double-wall pipes. Dry contact switching ensures dependability throughout its long service life. This reusable sensor easily fits small, interstitial spaces and senses liquid hydrocarbons or water. The unit is unaffected by hydrocarbon vapor, thereby reducing the risk of false alarms.

The LS-10 sensor's rounded design makes it easy to remove, clean and reinstall after an alarm condition is triggered, or for maintenance.

Dimensions

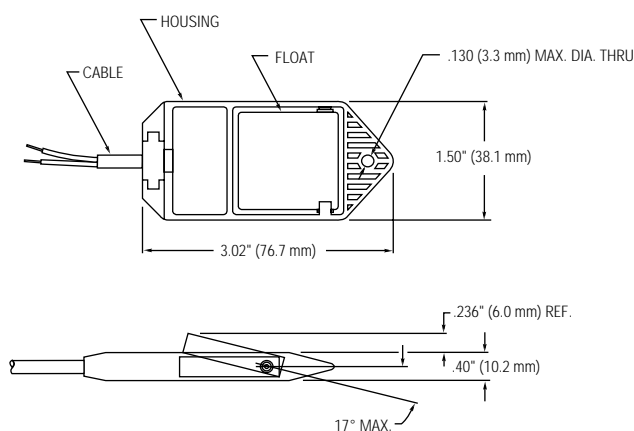

Specifications

Wetted Materials:

Housing: Valox®

Float: Foamed Polyethylene

Tape: UHB Double-Sided 3M Tape (p/n 160330 only)

Cable: PVC

Pressure: Atmospheric

Operating Temperature: -40°F to +176°F (-40°C to +80°C)

Accuracy: ±1/8 inch

Switch Rating: 10W, 50-120 VDC Resistive Only

Cable: Two (2) Conductor PVC Jacketed 24-26" Extended

Approvals: UL Recognized

How to Order – Select Part Number based on mounting option

Series Number	Mounting Option	Part Number
LS-10	With Double-Sided Tape	160330
	No Tape	160340 ⚡
	No Tape – 25' PVC Jacketed Cable	156000 ⚡

Note: The LS-10 sensor is a non-voltage producing device and does not contain energy storing components. However, since primary use is in hazardous locations, an appropriate intrinsically safe interface device is required for its use.



Typical Applications

- ▶ Fiberglass Double-Wall Tanks
- ▶ Containment Sumps
- ▶ Double Wall Pipes
- ▶ Piping Sumps

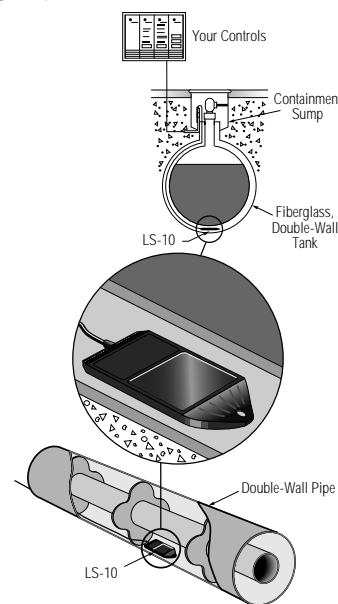

Typical Wiring Diagrams

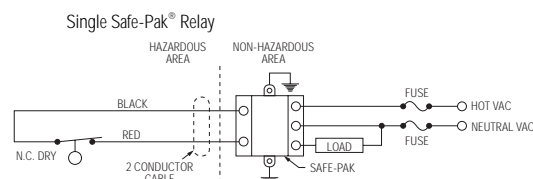
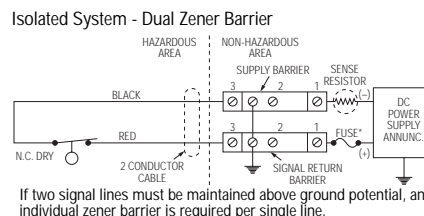
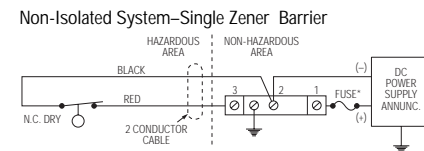

Safe-Pak® is an intrinsically safe, solid state relay