

ORDER IT!

Ordering is Easy! See Instructions on Page F-3.

DIPTAPE™ Indicators – Alloy Versions

- ▶ Temperatures to 300°F (148°C)
- ▶ Pressures to 750 PSI

Rugged brass or stainless steel units are ideal for use in water and oils. Select these units for best temperature and pressure capabilities.

1. Mounting Types

“B” Dimension (Length Overall):
Indicating Length + A + C

Note: Dimensions “C” and “A” are dependent on float selected. See Float Types below.

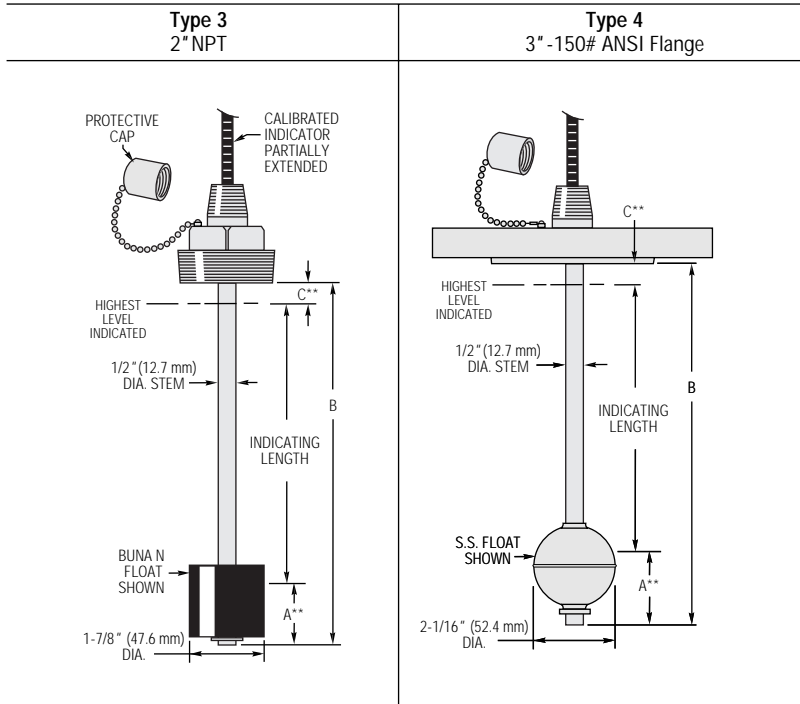

Stem and Mounting Material	Brass or 316 Stainless Steel	316 Stainless Steel Stem with Carbon Steel or 316 Stainless Steel Flange
Indicating Length*	6" to 72" (15.2 cm to 182.9 cm)	
Std. Indication Markings	1/16" and 1 mm increments	

* For longer lengths, please contact factory.
** Dimensions listed below, under “Float Types.”

2. Float Types

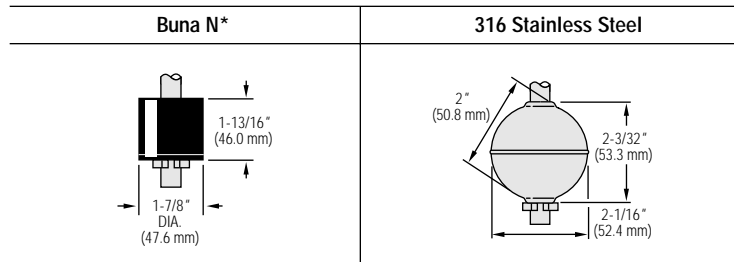

Float Part Number	73710	73709
Minimum Liquid Specific Gravity	.55	.80
Operating Temperatures	Oil: -40°F to 230°F (-40°C to +110°C) Water: to 180°F (+82.2°C)	-40°F to +300°F (-40°C to +148.8°C)
Operating Pressure, Max.	150 psi	750 psi (Mounting Type 3) 200 psi (Mounting Type 4)
“A” Dimension (From Mounting Types)	1-1/4" (31.7 mm)	1-3/8" (34.9 mm)
“C” Dimension (From Mounting Types)	11/16" (17.5 mm)	3/4" (19.05 mm)

*Other Wetted Material: Hysol.



LEVEL INDICATORS

Specifying and Ordering GEMS Custom DIPTAPE Indicators

Our OrderIt! Forms make it quick and easy.

1. To specify this product, start by photocopying the appropriate OrderIt! PRODUCT CHECK LIST located at the back of this catalog; Z-16.
2. Next, using the product information supplied in this section, check off the boxes and fill in the blanks of the OrderIt! Check List to specify your desired product configuration. Accurate answers to each question will assure correct fit and function of your custom built product. Note: Use a separate Check List for each unique configuration.
3. To obtain a priced quotation, Fax your completed OrderIt! Check List to Gems at 860-747-4244 or fax it to the Sales Office or Representative nearest you. All of our offices, along with their fax numbers, are conveniently located at the end of this catalog. Or, if you choose, mail it to us...We'll do the rest!
4. To order your CUSTOM product, either place your order over the phone with one of our representatives, or use the OrderIt! method. Just photocopy the OrderIt! ORDER SHEET found at the back of this catalog. Accurately complete all of the purchasing information that we'll need to process your order and fax it along with your OrderIt! PRODUCT CHECK LISTS. When using the Fax or mail method, the ORDER SHEET must be accompanied by the PRODUCT CHECK LISTS to expedite your order. These forms will provide us with the shipping and billing information we need, along with any prices or delivery dates quoted.



Don't hesitate to call a GEMS representative with questions, or for any clarification.

1-800-321-6070

(Outside of Continental U.S., 860-747-3000)